

# SET "MELANIA"



## AVANTGARDE Yarn

### MATERIALS ADRIAFIL YARNS

### DRESS

#### MATERIALS REQUIRED

150 g **Avantgarde** yarn, pink no. 03. Crochet hook 2.50. 140 cm. of pink satin ribbon (H 1 cm.) Tapestry needle with rounded tip

**AGE:** 2/3 years

#### PATTERN STITCHES

Chain  
Single crochet  
Double crochet  
Treble crochet  
Fancy stitch (see working instructions)

#### GAUGE

10 x 10 cm with crochet hook no. 2.50 in tr. work in rounds = 20 sts. and 10 rows.

#### WORKING INSTRUCTIONS

Work in two parts starting from the skirt (start working from the waistband). With crochet hook no. 2.50 cast on a 132 st. chain and, starting from the 4<sup>th</sup> chain on hook, work 2 rows in treble crochet in rounds (replace the 1<sup>st</sup> tr. of each row with 3 ch.); end each row with 1 sc. in the starting st. cont. as follows:

**Row 3:** \* 10 trs., skip 1 st., in the next st. work 2 trs., 2 ch. and 2 trs.; skip 1 st. \*, rep. from \* to \*.

**Row 4:** 1 sc. in the 1<sup>st</sup> tr., \* 9 trs., skip 1 st., 1 tr. in next st., in the space of 2 ch. work 2 trs., 2 ch. and 2 trs.; skip 1 tr. \*, rep. from \* to \*.

**Row 5:** 1 sc. in each of the first 2 trs., \* 6 trs., skip 1 st., 1 tr. in each of the 3 trs. seg., in the space of 2 ch. work 2 trs., 2 ch. and 2 trs.; 1 tr. in each of the next 3 trs., skip 2 trs. \*, rep. from \* to \*.

**Row 6:** 1 sc. in each of the first 2 trs., \* 3 trs., skip 1 st., 1 tr. in each of the the next 5 trs., in the space of 2 ch. work 2 trs., 2 ch. and 2 trs.; 1 tr. in each of the the next 5 trs., skip 2 trs. \*, rep. from \* to \*.

**Row 7:** 1 sc. in the 1<sup>st</sup> tr., \* 1 tr., skip 1 st., 1 tr. in each of the the next 7 trs., in the space of 2 ch. work 2 trs., 2 ch. and 2 trs.; 1 tr. in each of the the next 7 trs., skip 1 tr. \*, rep. from \* to \*.

**Row 8:** 1 sc. in the 1<sup>st</sup> tr., \* 1 tr. in each of the next 9 trs., in the space of 2 ch. work 2 trs., 2 ch. and 2 trs.; 1 tr. in each of the next 9 trs., skip

1 tr. \*, rep. from \* to \*

**Row 9:** 1 sc. in the 1<sup>st</sup> tr., \* 1 tr. in each of the next 10 trs., in the space of 2 ch. work 2 trs., 2 ch. and 2 trs.; 1 tr. in each of the next 10 trs., skip 1 tr. \*, rep. from \* to \*.

**from row 10 to row 18:** cont. with work as established, increasing, the number of trs. in every segment of 1 tr. at every row until work is finished.

**Row 19:** (trim) \* 1 dc., skip 2 sts., in the next st. work 4 trs., skip 2 sts. \*, rep. from \* to \*; break off and bind the yarn.

For the bodice (which is worked in rounds starting from left side) pick up work along the starting edge of the skirt and work as follows:

**Row 1:** hook yarn in side edge of the skirt (= start of rows) and work 93 trs; replace the 1<sup>st</sup> tr. of each row with 3 ch. and end each row with 1 sc. in the starting st.

**from row 2 to row 6:** 1 tr. in each st. below

**Row 7:** for the fancy stitch (= front of bodice) cont. as follows: 6 trs., \* 3 trs., 1 slanted tr. (= point crochet hook into the same base of the 1<sup>st</sup> tr. worked and then work 1 tr. winding the 3 sts. just worked) \*, rep. from \* to \* another 12 times, then finish the row in treble crochet

**Row 8:** 4 trs., rep. from \* to \* for a total of 17 motifs in fancy st., then finish the row in treble crochet.

**Row 9:** 2 trs., rep. from \* to \* for a total of 19 motifs in fancy st., then finish the row in treble crochet.

Cont. in treble crochet for 4 rows (= total of 13 rows, equal to 13 cm. of the bodice), then break off and bind the yarn.

To shape the shoulder pads, hook the yarn in the 7<sup>th</sup> st. (count starting from the left side towards back) and work 39 trs. (= back centre); turn over work and cont. for the right shoulder pad only over the 10 next sts.; work in treble crochet back and forth for 23 cm., then break off and bind the yarn. For the left shoulder pad, pick up work in the 1<sup>st</sup> of the 39 trs. of the back and work 10 trs. for 23 cm.; at end, without breaking off the yarn, trim the edges of the shoulder pads and the back and front neckline as follows: \* 1 dc., skip 2 sts. (or 1 row of the vertical edges), in the next st. work 4 trs., skip 2 m. (oppure 1 rows of the vertical edges) \*, rep. from \* to \*; end the row with 1 sc. in the starting st. Break off and bind the yarn.

#### MAKE UP AND FINISH

Cut two 30 cm lengths and 1 80 cm. lengths from the satin ribbon. Tie the first two lengths into a ribbon and with these, join the shoulder pads to the front bodice, at 3.5 cm from the side. Braod in the long piece of ribbon in the second row of the bodice and tie up into a ribbon at the centre of the front.

### Jersey pattern

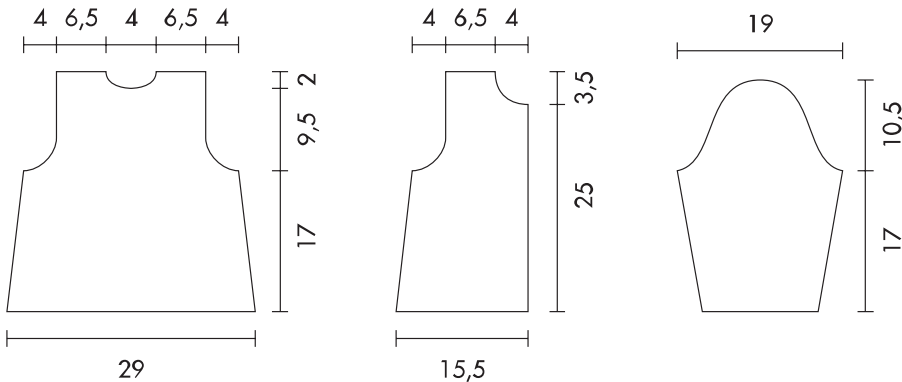

### Hat pattern

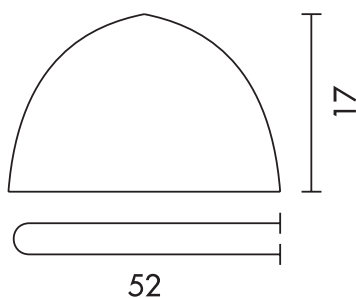

### Dress pattern

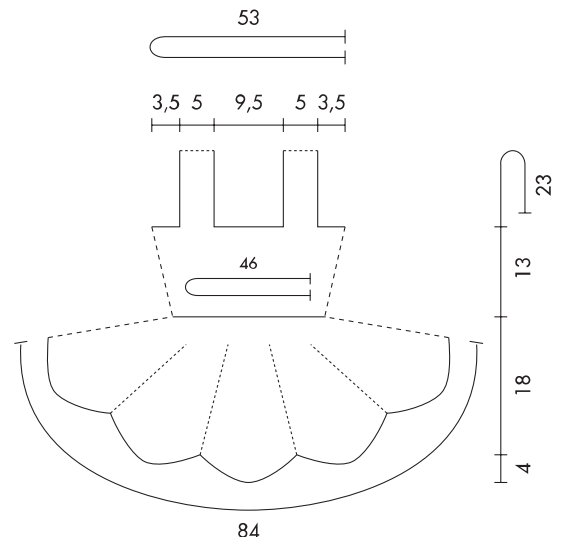

# SET "MELANIA"

## AVANTGARDE Yarn



### JERSEY

#### MATERIALS REQUIRED

A total of 150 g Avantgarde yarn in the following colours: 100 g. in pink no. 03 and 50 g in white no. 02. Crochet hook no. 2.50. 60 cm. pink satin ribbon (H 1 cm.). Tapestry needle with rounded tip.

**SIZE:** 2/3 years

#### PATTERN STITCHES

Chain

Single crochet

Double crochet

Treble crochet

Flower stitch (total number of stitches must be a multiple of 3 + 1):

**Row 1:** \* 3 trs. closed tog., 3 chains, 2 tr. closed tog. fitting the crochet hook into the closing of the prev. 3 trs. closed tog. \*, rep. from \* to \*, 1 tr.

**Row 2:** 1 tr. into 1<sup>st</sup> tr., \* 3 trs. into closure of 3 trs. closed tog. below, skip the group of 2 horizontal sts. \*, rep. from \* to \*, 1 tr. into closure of the last 3 sts. closed tog.

#### GAUGE

10 x 10 cm. with crochet hook no. 2.50 in tr. = 21 sts. and 10.5 row.

#### WORKING INSTRUCTIONS

**Back:** with crochet hook no. 2.50 and the pink cast on 63 sts. and, as from the 4<sup>th</sup> chain on the crochet hook, work alternating the stitches as follows: \* 4 rows in tr., 2 rows in flower st. working at the sides, 5 trs. (= 17 motifs in flower st.) \*, rep. from \* to \* fino at the end of work. At the same time, dec. at the sides, 1 st. every 4 rows 4 times. When work measures 17 cm. from beg., to shape the armholes stand off the work over the 4 side sts. and dec. 1 tr. every row 5 times. When work measures 9.5 cm. from beg. of armholes, to shape the neckline, stand off work over the 5 centre sts. and finish the two parts separately; stand off work again, centrewise, on 1 st. in next row. At 2 cm. from beg. of neckline, stand off the work over the rem. stitches for each shoulder.

**Right front:** with crochet hook no. 2.50 and the pink cast on 35 sts. and, as from the 4<sup>th</sup> chain on the crochet hook, work alternating the stitches in the same way as back, but working the 2<sup>nd</sup>, the 3<sup>rd</sup> and the 4<sup>th</sup> band in flower st. with the white, and in the 1<sup>st</sup> band in flower st., work at the sides, 4 trs. (= 8 motifs in flower st.). At the same time, dec. on left of work 1 st. after their 1<sup>st</sup> band in flower st. When work measures 17 cm. from beg., work the neckline on left of work in the same way as back. When work measures 25 cm. from beg., to shape the neckline, stand off the work on the right, on the first 7 sts. and, after 2 rows, over the other 2 sts. When work measures 3.5 cm. from beg. of neckline, stand off the work over the rem. stitches for the shoulder.

**Left front:** work to match the right front.

**Sleeves:** with crochet hook no. 2.50 and the pink yarn cast on 34 sts. and, as from the 4<sup>th</sup> chain on the crochet hook, work alternating the stitches in the same way as back, but working all the bands in flower st. with the white yarn, in the 1<sup>st</sup> band in flower st. work, at the sides, 2 tr. (= 9 motifs in flower st.). At the sides, inc. 1 st. every 4 rows 4 times and, in the respective bands, work these new stitches in tr. and, gradually as the work permits in flower st. When work measures 17 cm. from beg., to shape the armholes stand off the work over the 3 side sts. and dec. 1 tr. every row 10 times. When work measures 10.5 cm. from beg. of armholes, stand off the work over the rem. stitches.

#### MAKE UP AND FINISH

Sew up the shoulders. Join and sew on the sleeves. Sew up the sides. With crochet hook no. 2.50 and the pink yarn trim all the edges as follows: \* 1 dc., skip 1 st. (or 1 row of the vertical edges), in the next st. work 4 trs., skip 1 st. (or 1 row of the vertical edges) \*, rep. from \* to \*, end the row with 1 sc. in the initial st., then break off and bind the yarn. Cut off 4 - 15 cm. length of ribbon; sew on the front buttoning sides, 2 on each side, at 3 cm. and at 10 cm. from beg. of neckline and make a ribbon.

### HAT

#### MATERIALS REQUIRED

A total of 100 g. of Avantgarde yarn in 50 g of each of the following colours: white no. 02 and pink no. 03. Crochet hook no. 2.50. 60 cm. of pink satin ribbon (H 1 cm.). Two 5 cm ø stiff cardboard disks. Tapestry needle with rounded tip.

**DIMENSIONS:** circumference 52 cm.

#### PATTERN STITCHES

Chain

Single crochet

Double crochet

Half Treble

Treble crochet

**Bobble:** 3 trs., turn work over, fit crochet hook into the closure of the 1<sup>st</sup> tr., wind yarn over on hook, pulling out the yarn and passing it through the last st. rem. on the crochet hook; turn work over and cont. with the next bobble.

#### GAUGE

10 x 10 cm. with crochet hook no. 2.50 in bobble st. in rounds = 10 bobbles and 9.5 rows.

#### WORKING INSTRUCTIONS

**Hat:** work in rounds starting at the top. With crochet hook no. 2.50 and the white yarn cast on 5 st. chain, ending with a 1 sc. loop into the 1<sup>st</sup> chain and, in the loop obtained, work:

**Row 1:** (white) 22 tr. (repl. the 1<sup>st</sup> tr. of each row with 3 ch.); end this row and all the next rows with 1 sc. in the initial st.

**Row 2:** (white) in tr. increasing 11 sts. spaced evenly (= 33 sts.).

**Row 3:** (white) in tr. increasing 15 sts. spaced evenly (= 48 sts.).

**Row 4:** (white) in tr. increasing 15 sts. spaced evenly (= 63 sts.).

**Row 5:** (white) 3 chains, \* 1 bobble in each of the next 2 tr., 1 ch., skip 1 st. \*, rep. from \* to \* (= 42 bobbles).

**Row 6:** (pink) 3 chains, 1 bobble and 1 ch. between 1 bobble and the other bobble of the row below.

**Row 7:** (white) 3 chains, 1 bobble and 1 ch. between 1 bobble and the other bobble of the row below

**Row 8:** (pink) 3 chains, 1 bobble and 1 ch. between 1 bobble and the other bobble of the row below

**Row 9:** (white) 3 chains, \* (1 bobble and 1 ch. between 1 bobble and the other bobble of the row below) twice, 2 bobbles separated by 1 ch. between 1 bobble and the other bobble of the row below \*, rep. from \* to \*.

**Row 10:** (pink) 3 chains, 1 bobble and 1 ch. between 1 bobble and the other bobble of the row below

**Row 11:** (white) 3 chains, 1 bobble and 1 ch. between 1 bobble and the other bobble of the row below

**Row 12:** (pink) 3 chains, 1 bobble and 1 ch. between 1 bobble and the other bobble of the row below

Finish with the pink yarn.

**Row 13:** 2 tr. in each space of 1 ch. below

**Rows 14 and 15:** 1 tr. in each tr. below

**Row 16:** in tr. increasing 22 sts. spaced evenly.

**Row 17:** \* 1 dc., skip 1 st., in the next st. work 4 trs., skip 1 st. \*, rep. from \* to \*.

Break off and bind the yarn.

**Rose:** work in two separate parts. For the centre, with crochet hook no. 2.50 and the white yarn cast on an 8 st. chain, ending with a 1 sc. loop into the 1<sup>st</sup> chain and, in the loop obtained, work:

**Row 1:** 2 ch., 17 double tr.; end the row with 1 sc. in the initial st.; break off and bind the yarn.

For the petals: with crochet hook no. 2.50 and the pink yarn cast on a 12 st. chain, ending with a 1 sc. loop into the 1<sup>st</sup> chain and, in the loop obtained, work:

**Row 1:** 21 trs. (repl. the 1<sup>st</sup> tr. of each row with 3 ch.); end this row and all the next rows with 1 sc. in the initial st.

**Row 2:** \* 1 double tr. passing the crochet hook, from back to front, around the stem of the next tr., 3 chains, skip 2 m. \*, rep. from \* to \*.

**Row 3:** in the 1<sup>st</sup> loop below work 1 dc., 5 trs., 1 double tr. without closing, \* in the next loop work 1 double tr. closed tog. with prev., 5 trs., 1 double tr. without closing \*, rep. from \* to \* and end the last loop with 1 dc.

**Row 4:** \* 1 double tr. passing the crochet hook, from back to front, around the stem of the next double tr. of the 2<sup>nd</sup> row, 4 chains \*, rep. from \* to \*.

**Row 5:** in the 1<sup>st</sup> loop below, work 1 dc., 6 trs., 1 double tr. without closing, \* in the next loop work 1 double tr. closed tog. with prev., 6 trs., 1 double tr. without closing \*, rep. from \* to \* and end the last loop with 1 dc.

Break off and bind the yarn. Overlap the centre to the petals and fasten with small invisible stitches.

#### MAKE UP AND FINISH

With the pink yarn, make 1 pom-pom: make a 1.5 cm. diam. hole at the centre of the stiff cardboard disk; fit the two rings together, wrapping the yarn around the rings (using a tapestry needle) filling the hole at the centre. Pass the yarn between the two rings and cut a long length of yarn. With a very sharp pair of scissors, cut the threads wound around the rings inserting the tip of the scissors between the two rings (from the circumference side). Separate the rings slightly, wrap the threads around the bundle of threads at the centre between the two rings, pull the length of yarn firmly, then fasten with several stitches at the centre. Slide out the rings and puff up the pom-pom, evening it off with a pair of scissors, then fix at the top of the hat. Cut 2 30 cm. lengths of satin ribbon; fold on right side of work the last 3 rows of the hat, and fasten the fold on two opposite ends with the ribbon tied into a bow. Fasten the roses at the centre of the fronts and above the folded edge.